



KONICA MINOLTA

SERVICE MANUAL

FIELD SERVICE

bizhub C351

This service manual is issued for C351 that has been changed from C450. Therefore please refer it along with the service manual of C450.

SAFETY AND IMPORTANT WARNING ITEMS

Read carefully the Safety and Important Warning Items described below to understand them before doing service work.

IMPORTANT NOTICE

Because of possible hazards to an inexperienced person servicing this product as well as the risk of damage to the product, KONICA MINOLTA BUSINESS TECHNOLOGIES, INC. (hereafter called the KMBT) strongly recommends that all servicing be performed only by KMBT-trained service technicians.



Changes may have been made to this product to improve its performance after this Service Manual was printed. Accordingly, KMBT does not warrant, either explicitly or implicitly, that the information contained in this Service Manual is complete and accurate.

The user of this Service Manual must assume all risks of personal injury and/or damage to the product while servicing the product for which this Service Manual is intended.



Therefore, this Service Manual must be carefully read before doing service work both in the course of technical training and even after that, for performing maintenance and control of the product properly.

Keep this Service Manual also for future service.













DESCRIPTION ITEMS FOR DANGER, WARNING AND CAUTION

In this Service Manual, each of three expressions “ **DANGER**”, “ **WARNING**”, and “ **CAUTION**” is defined as follows together with a symbol mark to be used in a limited meaning.

When servicing the product, the relevant works (disassembling, reassembling, adjustment, repair, maintenance, etc.) need to be conducted with utmost care.

-  **DANGER:** Action having a high possibility of suffering death or serious injury
-  **WARNING:** Action having a possibility of suffering death or serious injury
-  **CAUTION:** Action having a possibility of suffering a slight wound, medium trouble, and property damage

Symbols used for safety and important warning items are defined as follows:

	:Precaution when servicing the product.		General precaution		Electric hazard		High temperature
	:Prohibition when servicing the product.		General prohibition		Do not touch with wet hand		Do not disassemble
	:Direction when servicing the product.		General instruction		Unplug		Ground/Earth

SAFETY WARNINGS

[1] MODIFICATIONS NOT AUTHORIZED BY KONICA MINOLTA BUSINESS TECHNOLOGIES, INC.

KONICA MINOLTA brand products are renowned for their high reliability. This reliability is achieved through high-quality design and a solid service network. Product design is a highly complicated and delicate process where numerous mechanical, physical, and electrical aspects have to be taken into consideration, with the aim of arriving at proper tolerances and safety factors. For this reason, unauthorized modifications involve a high risk of degradation in performance and safety. Such modifications are therefore strictly prohibited. The points listed below are not exhaustive, but they illustrate the reasoning behind this policy.

Prohibited Actions

⚠ DANGER

- Using any cables or power cord not specified by KMBT.

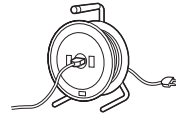

- Using any fuse or thermostat not specified by KMBT. Safety will not be assured, leading to a risk of fire and injury.

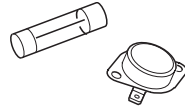

- Disabling fuse functions or bridging fuse terminals with wire, metal clips, solder or similar object.

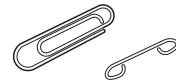

- Disabling relay functions (such as wedging paper between relay contacts)

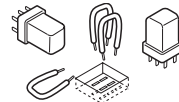

- Disabling safety functions (interlocks, safety circuits, etc.) Safety will not be assured, leading to a risk of fire and injury.

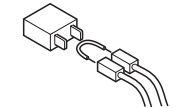

- Making any modification to the product unless instructed by KMBT



- Using parts not specified by KMBT

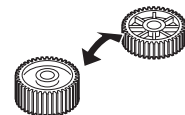

[2] POWER PLUG SELECTION

In some countries or areas, the power plug provided with the product may not fit wall outlet used in the area. In that case, it is obligation of customer engineer (hereafter called the CE) to attach appropriate power plug or power cord set in order to connect the product to the supply.

Power Cord Set or Power Plug

WARNING

- Use power supply cord set which meets the following criteria:
 - provided with a plug having configuration intended for the connection to wall outlet appropriate for the product's rated voltage and current, and
 - the plug has pin/terminal(s) for grounding, and
 - provided with three-conductor cable having enough current capacity, and
 - the cord set meets regulatory requirements for the area.

Use of inadequate cord set leads to fire or electric shock.
- Attach power plug which meets the following criteria:
 - having configuration intended for the connection to wall outlet appropriate for the product's rated voltage and current, and
 - the plug has pin/terminal(s) for grounding, and
 - meets regulatory requirements for the area.

Use of inadequate cord set leads to the product connecting to inadequate power supply (voltage, current capacity, grounding), and may result in fire or electric shock.
- Conductors in the power cable must be connected to terminals of the plug according to the following order:
 - Black or Brown: L (line)
 - White or Light Blue: N (neutral)
 - Green/Yellow: PE (earth)

Wrong connection may cancel safeguards within the product, and results in fire or electric shock.



[3] CHECKPOINTS WHEN PERFORMING ON-SITE SERVICE

KONICA MINOLTA brand products are extensively tested before shipping, to ensure that all applicable safety standards are met, in order to protect the customer and customer engineer (hereafter called the CE) from the risk of injury. However, in daily use, any electrical equipment may be subject to parts wear and eventual failure. In order to maintain safety and reliability, the CE must perform regular safety checks.

1. Power Supply

Connection to Power Supply**⚠ WARNING**

- Check that mains voltage is as specified.
Connection to wrong voltage supply may result in fire or electric shock. 

- Connect power plug directly into wall outlet having same configuration as the plug.

Use of an adapter leads to the product connecting to inadequate power supply (voltage, current capacity, grounding), and may result in fire or electric shock.

If proper wall outlet is not available, advice the customer to contact qualified electrician for the installation.



- Plug the power cord into the dedicated wall outlet with a capacity greater than the maximum power consumption.
If excessive current flows in the wall outlet, fire may result. 

- If two or more power cords can be plugged into the wall outlet, the total load must not exceed the rating of the wall outlet.

If excessive current flows in the wall outlet, fire may result. 

- Make sure the power cord is plugged in the wall outlet securely.

Contact problems may lead to increased resistance, overheating, and the risk of fire. 

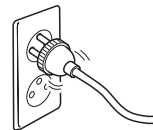

- Check whether the product is grounded properly.
If current leakage occurs in an ungrounded product, you may suffer electric shock while operating the product.
Connect power plug to grounded wall outlet. 

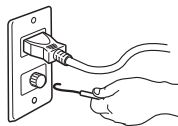

Power Plug and Cord

⚠ WARNING

- When using the power cord set (inlet type) that came with this product, make sure the connector is securely inserted in the inlet of the product.

When securing measure is provided, secure the cord with the fixture properly.

If the power cord (inlet type) is not connected to the product securely, a contact problem may lead to increased resistance, overheating, and risk of fire.

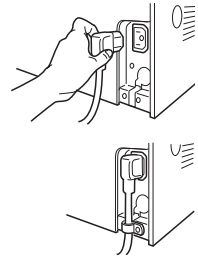

- Check whether the power cord is not stepped on or pinched by a table and so on.

Overheating may occur there, leading to a risk of fire.

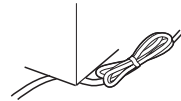

- Check whether the power cord is damaged. Check whether the sheath is damaged.

If the power plug, cord, or sheath is damaged, replace with a new power cord (with plug and connector on each end) specified by KMBT. Using the damaged power cord may result in fire or electric shock.

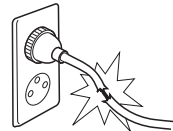

- Do not bundle or tie the power cord.

Overheating may occur there, leading to a risk of fire.

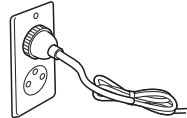

- Check whether dust is collected around the power plug and wall outlet.

Using the power plug and wall outlet without removing dust may result in fire.

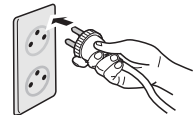

- Do not insert the power plug into the wall outlet with a wet hand.

The risk of electric shock exists.



- When unplugging the power cord, grasp the plug, not the cable.

The cable may be broken, leading to a risk of fire and electric shock.

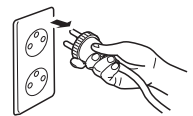

Wiring

WARNING

- Never use multi-plug adapters to plug multiple power cords in the same outlet.

If used, the risk of fire exists.

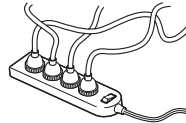

- When an extension cord is required, use a specified one. Current that can flow in the extension cord is limited, so using a too long extension cord may result in fire.

Do not use an extension cable reel with the cable taken up. Fire may result.



2. Installation Requirements

Prohibited Installation Places

WARNING

- Do not place the product near flammable materials or volatile materials that may catch fire.

A risk of fire exists.



- Do not place the product in a place exposed to water such as rain.

A risk of fire and electric shock exists.



When not Using the Product for a long time

WARNING

- When the product is not used over an extended period of time (holidays, etc.), switch it off and unplug the power cord.

Dust collected around the power plug and outlet may cause fire.

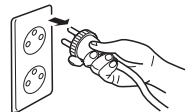

Ventilation

⚠ CAUTION

- The product generates ozone gas during operation, but it will not be harmful to the human body.

If a bad smell of ozone is present in the following cases, ventilate the room.

- a. When the product is used in a poorly ventilated room
- b. When taking a lot of copies
- c. When using multiple products at the same time

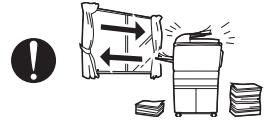

Stability

⚠ CAUTION

- Be sure to lock the caster stoppers.

In the case of an earthquake and so on, the product may slide, leading to a injury.



Inspection before Servicing

⚠ CAUTION

- Before conducting an inspection, read all relevant documentation (service manual, technical notices, etc.) and proceed with the inspection following the prescribed procedure, using only the prescribed tools. Do not make any adjustment not described in the documentation.

If the prescribed procedure or tool is not used, the product may break and a risk of injury or fire exists.



- Before conducting an inspection, be sure to disconnect the power plugs from the product and options.

When the power plug is inserted in the wall outlet, some units are still powered even if the POWER switch is turned OFF. A risk of electric shock exists.

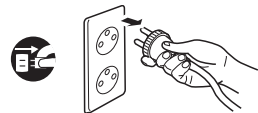

- The area around the fixing unit is hot.
You may get burnt.

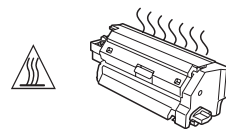

Work Performed with the Product Powered On**⚠ WARNING**

- Take every care when making adjustments or performing an operation check with the product powered.

If you make adjustments or perform an operation check with the external cover detached, you may touch live or high-voltage parts or you may be caught in moving gears or the timing belt, leading to a risk of injury.



- Take every care when servicing with the external cover detached.

High-voltage exists around the drum unit. A risk of electric shock exists.

**Safety Checkpoints****⚠ WARNING**

- Check the exterior and frame for edges, burrs, and other damage.

The user or CE may be injured.



- Do not allow any metal parts such as clips, staples, and screws to fall into the product.

They can short internal circuits and cause electric shock or fire.

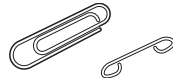

- Check wiring for squeezing and any other damage.

Current can leak, leading to a risk of electric shock or fire.



- Carefully remove all toner remnants and dust from electrical parts and electrode units such as a charging corona unit.

Current can leak, leading to a risk of product trouble or fire.



- Check high-voltage cables and sheaths for any damage.

Current can leak, leading to a risk of electric shock or fire.



Safety Checkpoints

WARNING

- Check electrode units such as a charging corona unit for deterioration and sign of leakage.

Current can leak, leading to a risk of trouble or fire.



- Before disassembling or adjusting the write unit (P/H unit) incorporating a laser, make sure that the power cord has been disconnected.

The laser light can enter your eye, leading to a risk of loss of eyesight.



- Do not remove the cover of the write unit. Do not supply power with the write unit shifted from the specified mounting position.

The laser light can enter your eye, leading to a risk of loss of eyesight.



- When replacing a lithium battery, replace it with a new lithium battery specified in the Parts Guide Manual. Dispose of the used lithium battery using the method specified by local authority.

Improper replacement can cause explosion.

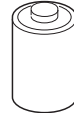

- After replacing a part to which AC voltage is applied (e.g., optical lamp and fixing lamp), be sure to check the installation state.

A risk of fire exists.

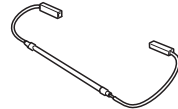

- Check the interlock switch and actuator for loosening and check whether the interlock functions properly.

If the interlock does not function, you may receive an electric shock or be injured when you insert your hand in the product (e.g., for clearing paper jam).

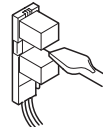

- Make sure the wiring cannot come into contact with sharp edges, burrs, or other pointed parts.

Current can leak, leading to a risk of electric shock or fire.



Safety Checkpoints

WARNING

- Make sure that all screws, components, wiring, connectors, etc. that were removed for safety check and maintenance have been reinstalled in the original location. (Pay special attention to forgotten connectors, pinched cables, forgotten screws, etc.)



A risk of product trouble, electric shock, and fire exists.

Handling of Consumables

WARNING

- Toner and developer are not harmful substances, but care must be taken not to breathe excessive amounts or let the substances come into contact with eyes, etc. It may be stimulative.

If the substances get in the eye, rinse with plenty of water immediately. When symptoms are noticeable, consult a physician.



- Never throw the used cartridge and toner into fire.
You may be burned due to dust explosion.



Handling of Service Materials

CAUTION

- Unplug the power cord from the wall outlet.
Drum cleaner (isopropyl alcohol) and roller cleaner (acetone-based) are highly flammable and must be handled with care. A risk of fire exists.

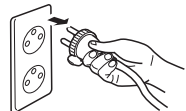

- Do not replace the cover or turn the product ON before any solvent remnants on the cleaned parts have fully evaporated.



A risk of fire exists.

Handling of Service Materials

CAUTION

- Use only a small amount of cleaner at a time and take care not to spill any liquid. If this happens, immediately wipe it off.
A risk of fire exists.



- When using any solvent, ventilate the room well.
Breathing large quantities of organic solvents can lead to discomfort.



[4] Used Batteries Precautions

ALL Areas

CAUTION

Danger of explosion if battery is incorrectly replaced.

Replace only with the same or equivalent type recommended by the manufacturer.

Dispose of used batteries according to the manufacturer's instructions.

Germany

VORSICHT!

Explosionsgefahr bei unsachgemäßem Austausch der Batterie.

Ersatz nur durch denselben oder einen vom Hersteller empfohlenen gleichwertigen Typ.

Entsorgung gebrauchter Batterien nach Angaben des Herstellers.

France

ATTENTION

Il y a danger d'explosion s'il y a remplacement incorrect de la batterie.

Remplacer uniquement avec une batterie du même type ou d'un type équivalent recommandé par le constructeur.

Mettre au rebut les batteries usagées conformément aux instructions du fabricant.

Denmark

ADVARSEL!

Lithiumbatteri - Eksplosionsfare ved fejlagtig håndtering.

Udskiftning må kun ske med batteri af samme fabrikat og type.

Levér det brugte batteri tilbage til leverandøren.

Finland, Sweden

VAROITUS

Paristo voi räjähtää, jos se on virheellisesti asennettu.

Vaihda paristo ainoastaan laitevalmistajan suosittelemaan tyyppiin.

Hävittä käytetty paristo valmistajan ohjeiden mukaisesti.

VARNING

Explosionsfara vid felaktigt batteribyte.

Använd samma batterityp eller en ekvivalent typ som rekommenderas av apparattillverkaren.

Kassera använt batteri enligt fabrikantens instruktion.

Norway

ADVARSEL

Eksplosjonsfare ved feilaktig skifte av batteri.

Benytt samme batteritype eller en tilsvarende type anbefalt av apparatfabrikanten.

Brukte batterier kasseres i henhold til fabrikantens instruksjoner.

[5] FUSE

CAUTION
Double pole / neutral fusing

ATTENTION
Double pôle / fusible sur le neutre.

[6] LED Radiation Safety

- This product is a copier which operates by means of a LED (light emitting diodes) exposure system. There is no possibility of danger from the LED optical radiation, because the LED optical radiation level dose not exceed the accessible radiation limit of class 1 under all conditions of operation, maintenance, service and failure.

WARNING INDICATIONS ON THE MACHINE

Caution labels shown are attached in some areas on/in the machine.
When accessing these areas for maintenance, repair, or adjustment, special care should be taken to avoid burns and electric shock.

 **High voltage**

 **High temperature**

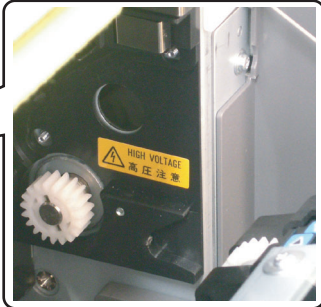
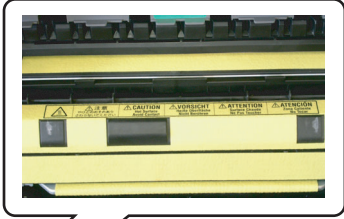

 **High voltage**

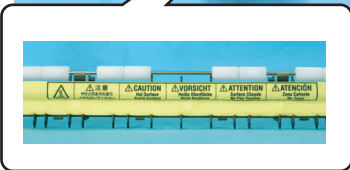

 **High temperature**

4037P0C501DA

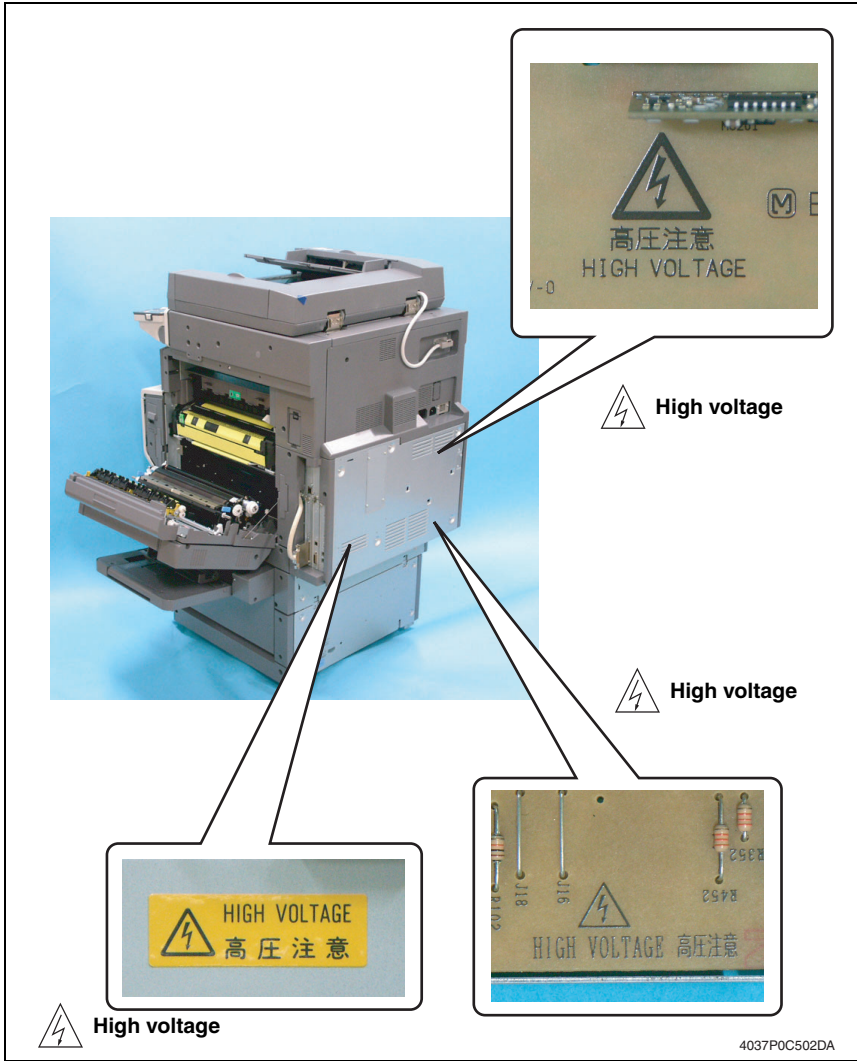

WARNING
 △ WARNING △ ATTENTION
 △ WARNUNG △ 警告
 △ ATENCIÓN △ 경고
 △ AVVERTENZA △ انتذار
 △ AVISO

HIGH VOLTAGE
 高压注意

TONER YELLOW
 Net Weight 230g (8.11oz)
 MADE IN JAPAN

WARNING
 △ WARNING △ ATTENTION
 △ WARNUNG △ 警告
 △ ATENCIÓN △ 경고
 △ AVVERTENZA △ انتذار
 △ AVISO

High voltage

4037P0C503DA

⚠ CAUTION:

- You may be burned or injured if you touch any area that you are advised not to touch by any caution label. Do not remove caution labels. If any caution label has come off or soiled and therefore the caution cannot be read, contact our Service Office.

MEASURES TO TAKE IN CASE OF AN ACCIDENT

1. If an accident has occurred, the distributor who has been notified first must immediately take emergency measures to provide relief to affected persons and to prevent further damage.
2. If a report of a serious accident has been received from a customer, an on-site evaluation must be carried out quickly and KMBT must be notified.
3. To determine the cause of the accident, conditions and materials must be recorded through direct on-site checks, in accordance with instructions issued by KMBT.
4. For reports and measures concerning serious accidents, follow the regulations specified by every distributor.

Composition of the service manual

This service manual consists of Theory of Operation section and Field Service section to explain the main machine and its corresponding options.

Theory of Operation section gives, as information for the CE to get a full understanding of the product, a rough outline of the object and role of each function, the relationship between the electrical system and the mechanical system, and the timing of operation of each part.

Field Service section gives, as information required by the CE at the site (or at the customer's premise), a rough outline of the service schedule and its details, maintenance steps, the object and role of each adjustment, error codes and supplementary information.

The basic configuration of each section is as follows. However some options may not be applied to the following configuration.

<Theory of Operation section>

OUTLINE:	Explanation of system configuration, product specifications, unit configuration, and paper path
COMPOSITION/OPERATION:	Explanation of configuration of each unit, operating system, and control system

<Field service section>

OUTLINE:	Explanation of system configuration, and product specifications
MAINTENANCE:	Explanation of service schedule, maintenance steps, service tools, removal/reinstallation methods of major parts, and firmware version up method etc.
ADJUSTMENT/SETTING:	Explanation of utility mode, service mode, and mechanical adjustment etc.
TROUBLESHOOTING:	Explanation of lists of jam codes and error codes, and their countermeasures etc.
APPENDIX:	Parts layout drawings, connector layout drawings, timing chart, overall layout drawing are attached.

Notation of the service manual

A. Product name

In this manual, each of the products is described as follows:

- | | |
|---------------------------|------------------------------|
| (1) PWB-MC: | Control Board |
| (2) bizhub C351: | Main body |
| (3) Microsoft Windows 95: | Windows 95 |
| Microsoft Windows 98: | Windows 98 |
| Microsoft Windows Me: | Windows Me |
| Microsoft Windows NT 4.0: | Windows NT 4.0 or Windows NT |
| Microsoft Windows 2000: | Windows 2000 |
| Microsoft Windows XP: | Windows XP |

When the description is made in combination of the OS's mentioned above:

Windows 95/98/Me
Windows NT 4.0/2000
Windows NT/2000/XP
Windows 95/98/Me/ NT/2000/XP

B. Brand name

The company names and product names mentioned in this manual are the brand name or the registered trademark of each company.



KONICA MINOLTA

SERVICE MANUAL

FIELD SERVICE

bizhub C351

Main Unit





Revision history

After publication of this service manual, the parts and mechanism may be subject to change for improvement of their performance.

Therefore, the descriptions given in this service manual may not coincide with the actual machine.

When any change has been made to the descriptions in the service manual, a revised version will be issued with a revision mark added as required.

Revision mark:

- To indicate clearly a section revised, show  to the left of the revised section.
A number within  represents the number of times the revision has been made.
- To indicate clearly a section revised, show  in the lower outside section of the corresponding page.
A number within  represents the number of times the revision has been made.

NOTE

Revision marks shown in a page are restricted only to the latest ones with the old ones deleted.

- When a page revised in Ver. 2.0 has been changed in Ver. 3.0:
The revision marks for Ver. 3.0 only are shown with those for Ver. 2.0 deleted.
- When a page revised in Ver. 2.0 has not been changed in Ver. 3.0:
The revision marks for Ver. 2.0 are left as they are.

2005/05	1.0	—	Issue of the first edition
Date	Service manual Ver.	Revision mark	Descriptions of revision

CONTENTS

General

1.	System configuration.....	1
2.	Product specifications	3

Maintenance

3.	Periodical check	7
3.1	Service schedule	7
3.2	Concept of parts life.....	7
4.	Firmware upgrade	8
4.1	Preparations for Firmware rewriting.....	8
4.1.1	Service environment	8
4.1.2	Application to be used.....	8
4.1.3	Installing the Cygwin	8
4.1.4	Writing into the Compact flash	11
5.	Other	14
5.1	Special Parts of C351	14
5.2	Special Parts List.....	14

Adjustment/Setting

6.	Service Mode	15
6.1	Machine	15
6.1.1	Fusing Temperature	15
6.1.2	Fusing Transport Speed.....	16
6.1.3	Printer Resist Loop	16

Troubleshooting

7.	Jam Display	17
7.1	Solution.....	17
7.1.1	Tray 1 take-up, 2nd Image Transfer, Fusing Misfeed.....	17

Appendix

8.	Parts layout drawing.....	19
8.1	DF-601 (Option).....	19
9.	Timing chart	20
9.1	DF-601 (Option).....	20

bizhub C351

General

Maintenance

Adjustment / Setting

Troubleshooting

Appendix

Blank Page

General

1. System configuration

1/2 System Front View

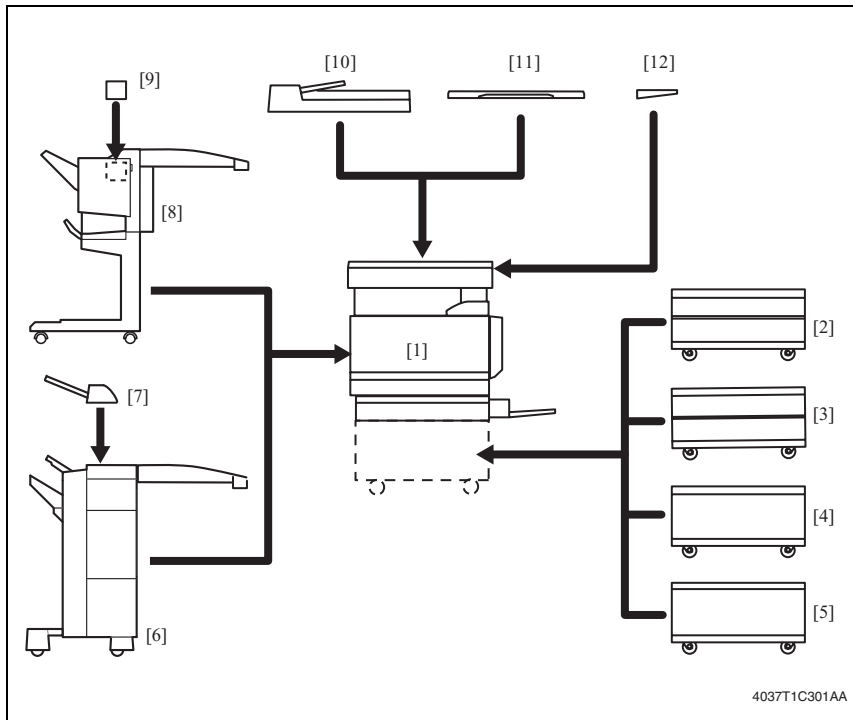

- | | |
|-------------------------------|---|
| [1] Machine | [7] Job Separator JS-601 |
| [2] Paper Feed Cabinet PC-202 | [8] Finisher FS-603 |
| [3] Paper Feed Cabinet PC-102 | [9] Punch Kit PK-501 |
| [4] Paper Feed Cabinet PC-402 | [10] Reverse Automatic Document Feeder DF-601 |
| [5] Desk DK-501 | [11] Original Cover OC-501 |
| [6] Finisher FS-507 | [12] Working Table WT-501 |

2/2 System Rear View

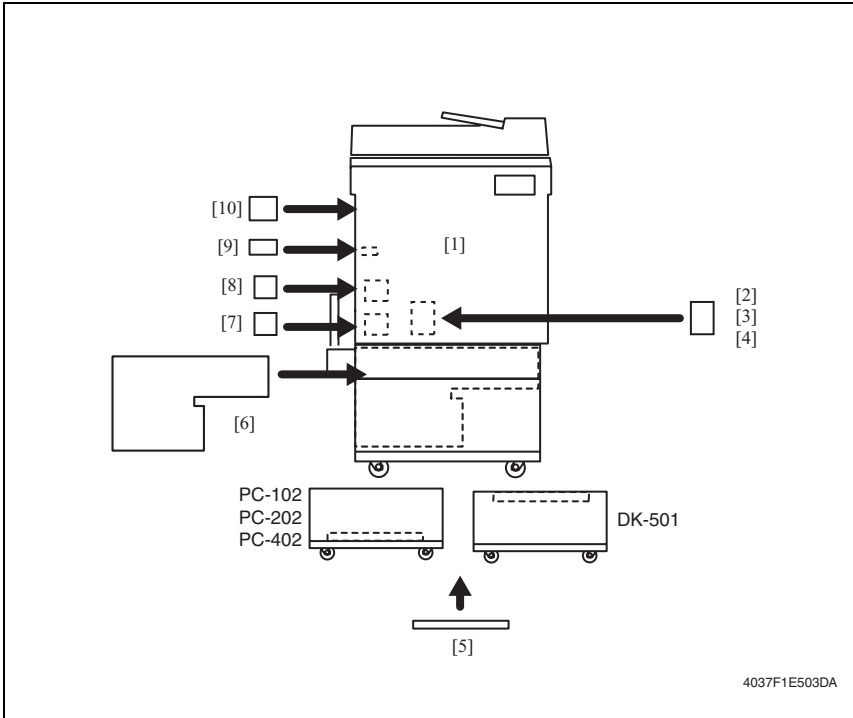

- | | |
|----------------------------|--------------------------------|
| [1] Machine | [6] Image Controller IC-402 |
| [2] Fax Kit FK-502 | [7] Video Interface Kit VI-502 |
| [3] Mount Kit MK-703 | [8] Local Interface Kit EK-702 |
| [4] Mount Kit MK-704 | [9] Mechanical Counter MC-501 |
| [5] Dehumidifier Heater 1C | [10] Key Counter Kit KIT-1 |

4037F1E503DA

2. Product specifications

A. Type

Type	Desktop-type printer integrated with scanner
Copying System	Electrostatic dry-powdered image transfer to plain paper
Printing Process	Tandem-type indirect electrostatic recording system
PC Drum Type	OPC (organic photo conductor)
Scanning Density	Equivalent to 600 dpi
Exposure Lamp	White rare-gas fluorescent lamp 30 W
Print Density	Equivalent to 600 dpi in main scanning direction × 1800 dpi in sub scanning direction
Platen	Stationary (mirror scan)
Original Scanning	Scanning in main scanning direction with a CCD (one-shot reading system)
Registration	Rear left edge
Paper Feeding System (Standard)	Multiple Bypass: 150 sheets
Three-way system	Tray1: 250 sheets Tray2: 500 sheets
Exposure System	Four-LED exposure
Developing System	HMT developing system
Charging System	DC comb electrode Scorotron system with electrode cleaning function (manual)
Image Transfer System	Intermediate transfer belt system
Paper Separating System	Selecting either application of nonwoven fabric bias or resistor grounding + low-pressure paper separator claws
Fusing System	Belt fusing

B. Functions

Types of Original	Sheets, books, and three-dimensional objects	
Max. Original Size	A3 or 11 × 17	
Multiple Copies	1 to 999	
Warm-up Time	99 sec. or less (at ambient temperature of 23° C/73.4° F and rated source voltage)	
Image Loss	Leading edge: 4.2 mm (3/16 inch), Trailing edge: 3 mm (1/8 inch), Rear edge: 3 mm (1/8 inch), Front edge: 3 mm (1/8 inch)	
First Copy Time	(Tray1, A4, full size)	
	Black print	6.8 sec. or less
	Color print	8.5 sec. or less
Copying Speed for Multi-copy Cycle (A4, 8-1/2 × 11)	Black print	1-sided: 35 copies/min.; 2-sided: 31 copies/min.
	Color print	1-sided: 35 copies/min.; 2-sided: 31 copies/min.
Fixed Zoom Ratios	Full size	×1.000
	Reduction	Metric Area: ×0.500, ×0.707, ×0.816, ×0.866 Inch Area: ×0.500, ×0.647, ×0.733, ×0.785
		Enlargement
Variable Zoom Ratios	×0.250 to ×4.000	in 0.001 increments

C. Types of Paper

Paper Source		Tray1	Tray2	Multiple Bypass
Copy paper type	Plain paper (60 to 90 g/m ² / 16 to 24 lb)	○	○	○
	Translucent paper	–	–	–
	OHP transparencies (crosswise feeding only)	○ (20 sheets or less)	–	○ (20 sheets or less)
	Thick paper 1 (91 to 150 g/m ² / 24-1/4 to 40 lb)		○ (150 sheets or less)	
	Thick paper 2 (151 to 209 g/m ² / 40-1/4 to 55-1/2 lb)			
	Thick paper 3 (210 to 256 g/m ² / 55-3/4 to 68 lb) *1			
	Postcards		–	
	Envelopes	○ (10 sheets or less)	–	○ (10 sheets or less)
Labels	○ (20 sheets or less)	–	○ (20 sheets or less)	
Copy paper dimensions	Max. (width × length)	311.1 × 457.2 mm 12-1/4 × 18 inches	297 × 432 mm 11 × 17 inches	311.1 × 457.2 mm 12-1/4 × 18 inches
	Min. (width × length)	90 × 139.7 mm 3-1/2 × 5-1/2 inches	140 × 182 mm 5-1/2 × 8-1/2 inches	90 × 139.7 mm 3-1/2 × 5-1/2 inches

*1: Image is not guaranteed when thick paper 3 is used.

Optional Paper Feed Cabinet : Only the plain paper and thick paper 1 to 3 weighing 60 to 90 g/m² (16 to 24 lb) is reliably fed.

Automatic Duplex Unit : Only the plain paper and thick paper 1 to 3 weighing 64 to 90 g/m² (17 to 24 lb) is reliably fed.

D. Maintenance

Machine Durability	800,000 prints or 5 years, whichever is earlier
--------------------	---

E. Machine Specifications

Power Requirements	Voltage:	AC 110 V, 120 V, 127 V, 220-240 V
	Frequency:	50/60 Hz ± 3.0 Hz
Max Power Consumption	Less than 1500 W (120 V, 12 A / 220 - 240 V, 8 A)	
Dimensions	706 (W) × 765 (D) × 770 (H) mm 27-3/4 (W) × 30 (D) × 30-1/4 (H) inches	
Space Requirements	1014 (W) × 765 (D) mm *2 40 (W) × 30 (D) inches *2	
Mass	Approx. 111 kg / 244-3/4 lb (without IU)	

*2: The indicated spaced requirements represent the space required to fully extend the bypass tray.

F. Operating Environment

Temperature	10 to 30 °C / 50 to 86° F (with a fluctuation of 10° C / 18° F or less per hour)
Humidity	15 to 85 % (with a fluctuation of 20 %/h)

G. Built-in Controllers

Type	Built-in type controller	
CPU	PPC750 FX 600 MHz	
Printer Driver	PCL5e/c Emulation PCL6 (XL 2.1) Emulation PostScript 3 Emulation (3011)	
Scan Driver	TWAIN driver	
OS Compatibility	Server	Windows NT 4.0, 2000, or Server 2003
	Client	Windows 98 Second Edition, Windows Me, Windows 2000, Windows XP, or Windows NT 4.0 (SP6a) MacOS 9.2 or later or MacOS X 10.2 or 10.3
Interface	Standard: Ethernet (10Base-T or 100Base-TX) Optional: USB 1.1, USB 2.0, or IEEE 1284	

NOTE

- These specifications are subject to change without notice.

bizhub C351

General

Blank Page

Maintenance

3. Periodical check

3.1 Service schedule

Guarantee period (5-year or 800,000 prints)

	Per cycle × print number	× 10,000-print																Number of times			
		6	12	15	18	20	24	30	36	40	42	45	48	54	60	66	72		75	78	
Main body	Upon each call (60,000)	●	●		●			●	●	●		●		●	●	●	●		●		13
	150,000			●				●				●			●				●		5
	200,000					●				●					●						3
	300,000							●								●					2
PC-102 PC-202 PC-402	300,000							●							●						2
FS-507 FS-603	300,000							●							●						2

3.2 Concept of parts life

A. Conditions for Life Specifications Values

- The life specification values represent the number of copies made or figures equivalent to it when given conditions (see the Table given below) are met. They can be more or less depending on the machine operating conditions of each individual user.

Item	Description
Job Type	Monochrome: Making 4 copies per job Color: Making 4 copies per job
Paper Size	A4
Color Ratio	Black to Color = 5:1
CV/M	Black: 8,000 / Color: 1,600
Original Density	B/W = 5 % for each color, 6 % for Monochrome
No. of Operating Days per Month	20 days (Main Power Switch turned ON and OFF 20 times per month)

4. Firmware upgrade

4.1 Preparations for Firmware rewriting

4.1.1 Service environment

- OS: Windows 2000
- Drive which enables writing/reading of Compact flash
- Compact flash (with 128MB or more)

4.1.2 Application to be used

- Cygwin (Free software)

4.1.3 Installing the Cygwin

- The software for writing the Firmware into Compact flash is installed into the PC.

1. Double click the [setup.exe] on CD-ROM in which Cygwin is stored.



2. Click [Next (N)].

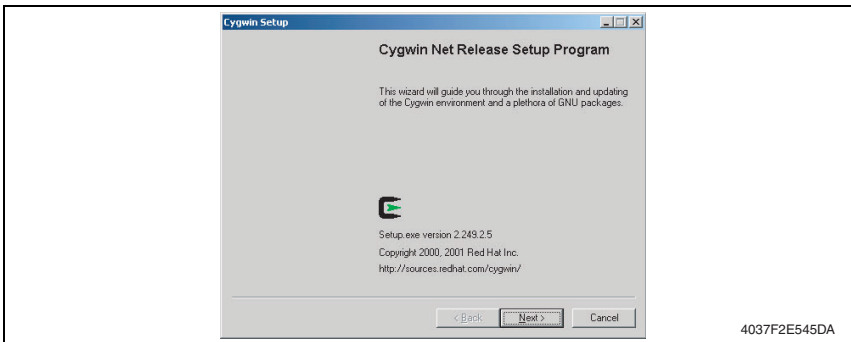

3. Select "Install from Local Directory", and click [Next (N)].

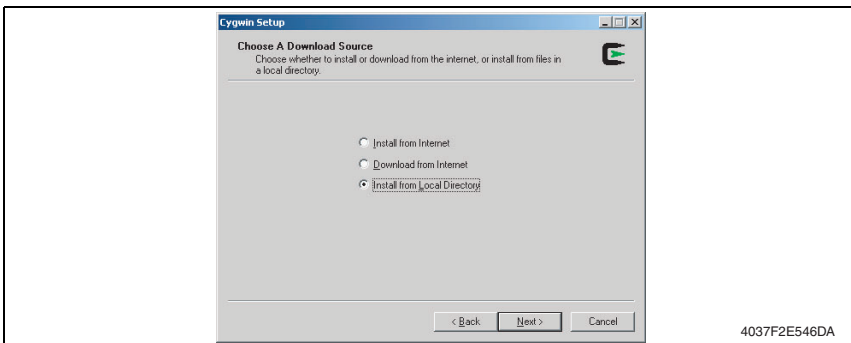

- Specify the folder for installation.
Check to make sure that “Root Directory” is in default setting, [C:\cygwin].

NOTE

- **Make sure to check that “Root Directory” is in default setting, [C:\cygwin].**
- **Do not change the setting value except “Root Directory.”**

- Click [Next (N)].

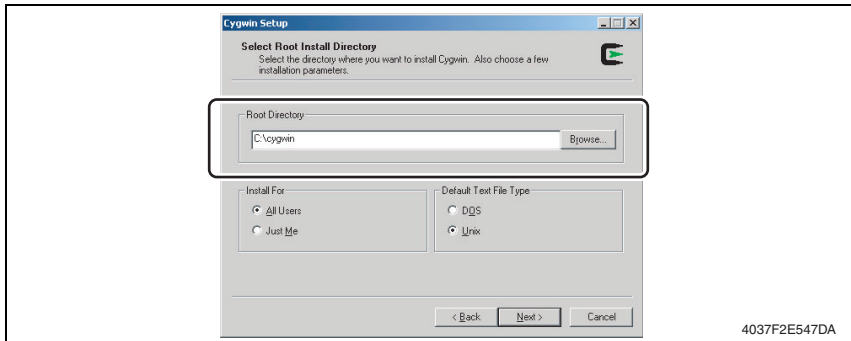

- Specify the place of the data to be installed.
For installing from CD-ROM, select the [cygwin] folder in CD-ROM drive.
(Described below is the sample procedure when CD-ROM drive is E-drive.)
- Click [Next (N)].

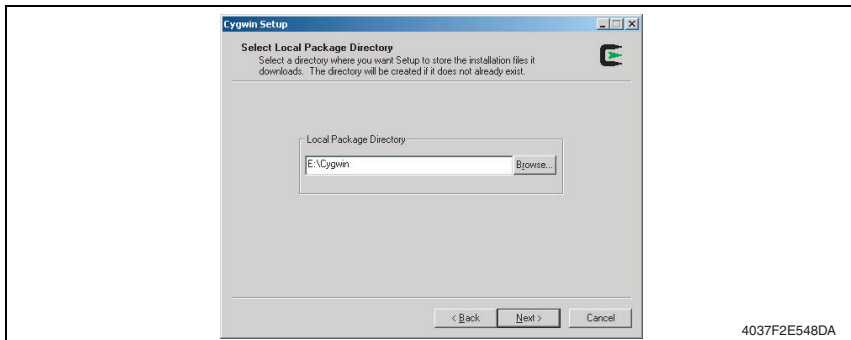

8. Click [Next (N)].

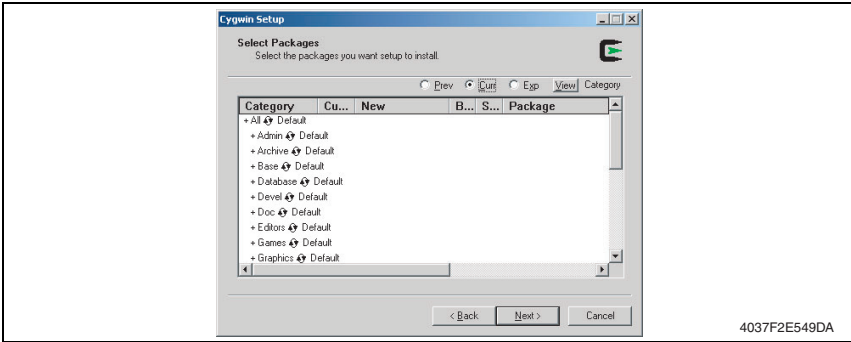

4037F2E549DA

9. Click [Complete] to start installing.

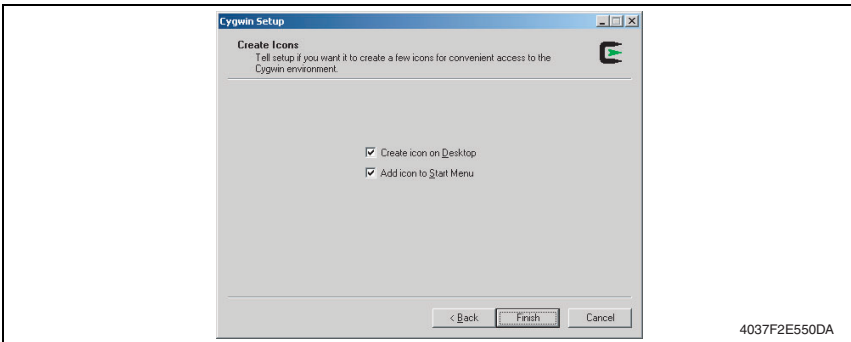

4037F2E550DA

10. After installing, open the Property of "My Computer", and click the "Environmental Variable" of "Advanced" tab.

11. Click the "New" in System Variable Setting.

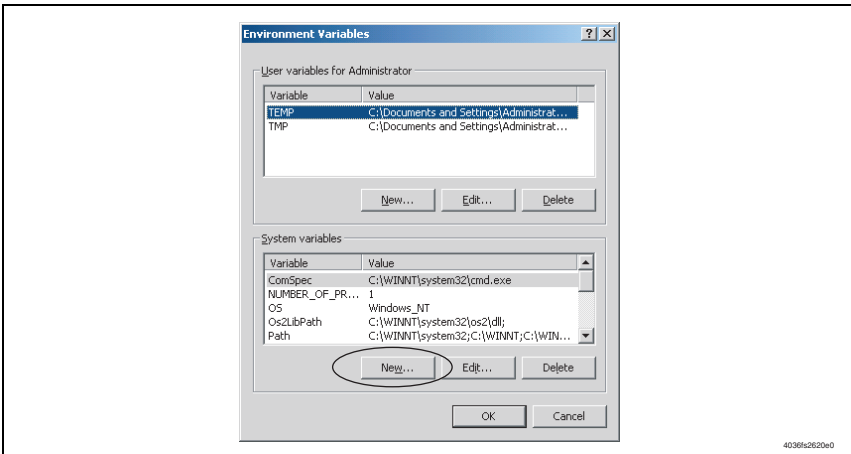

4036f2620e0

12. Set the following two values as the Windows Environmental Variable.

Variable name	Variable value
CYGWIN	ntsec
HOME	/home/username

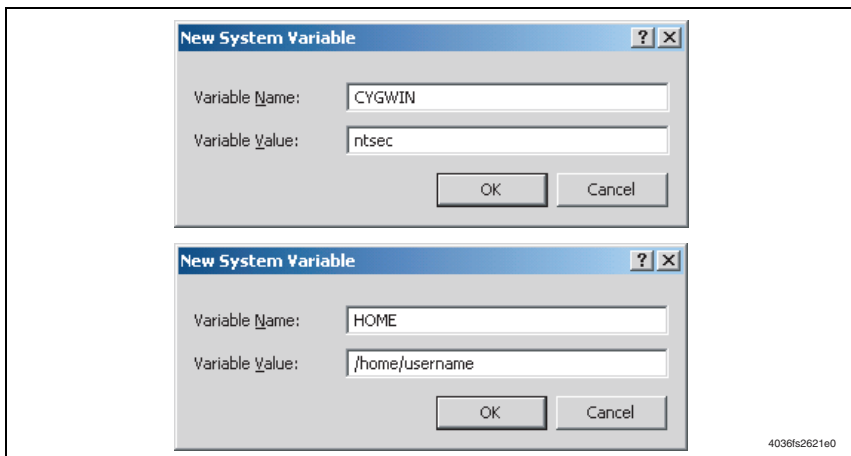

4.1.4 Writing into the Compact flash

1. Put the data of Firmware in the optional directory. (C:\C351 in the below figure)

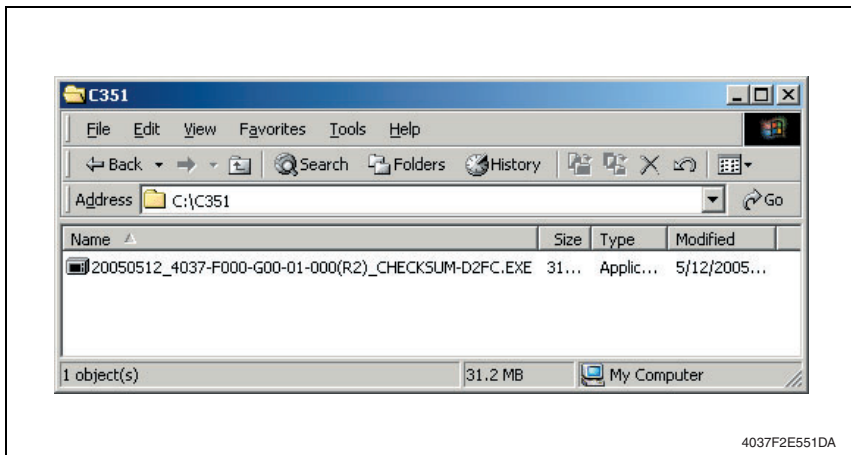

NOTE

- The file name of Firmware data consists of the “Release Date_Version_CHECKSUM-****.exe.”

2. Double-click the Firmware data, and specify the directory to be uncompressed, and then uncompress it.

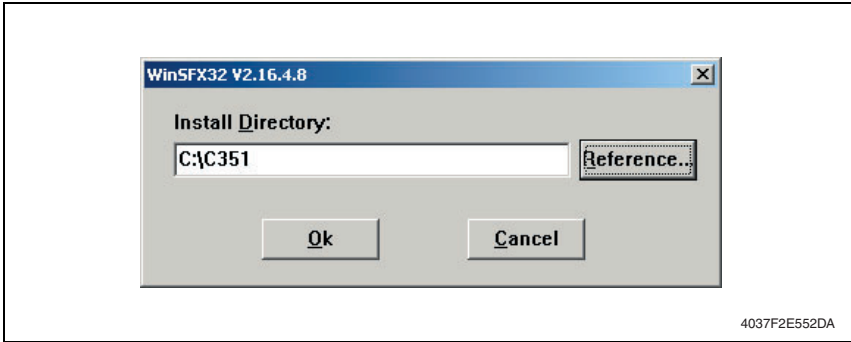
**NOTE**

- When old Firmware is still left in the specified directory to be uncompressed, delete it before uncompressing.
3. Mount the Compact flash on the PC, and check the Drive name, which was recognized in the Windows. (F-drive in the following figure)

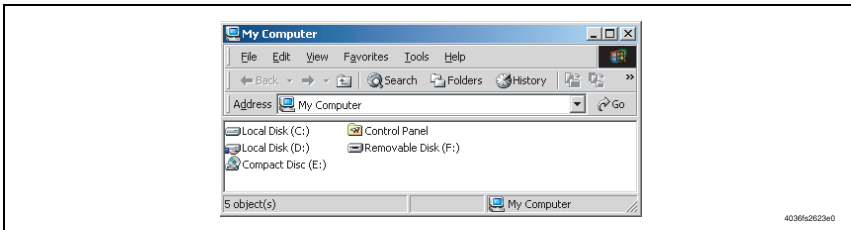

- Click “Start” → “Program” → “Accessories” → “Command Prompt” to open the Command Prompt.
- Use the Command prompt to move into the uncompressed directory.
- Specify the Drive of Compact flash, which was recognized through the procedure 3, and execute the “mkcf.bat.” (Input the C: \C351\card_work>mkcf f: in the below figure, and push the “Enter”.)

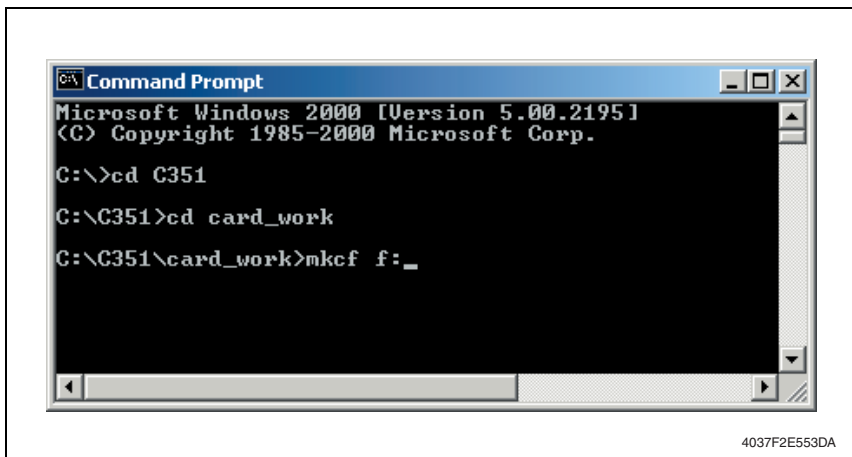

- Once the “mkcf.bat” is executed, data writing into the Compact flash is started.
- Upon completion of writing, CHECKSUM is executed. If CHECKSUM value is precisely matched, “VERIFY OK” appears.

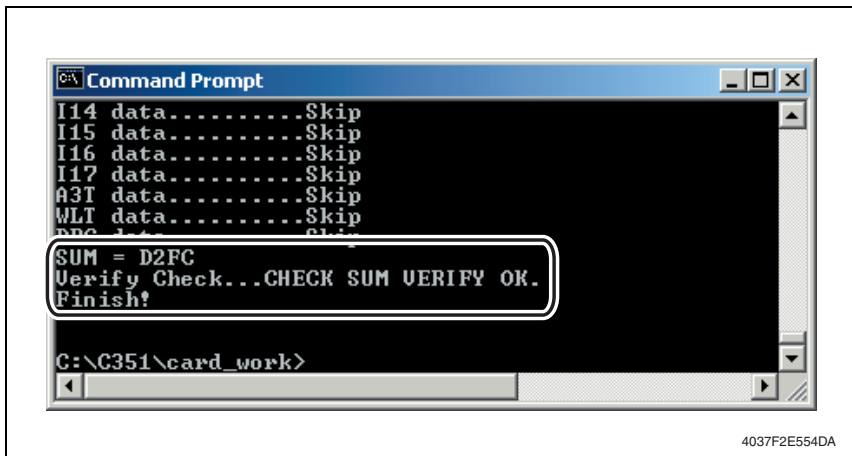

- Remove the Compact flash from PC.

NOTE

- When removing the Compact flash, be sure to check if data is written as normal and then remove it according to the precise removing method.

5. Other

5.1 Special Parts of C351

- Special components intended for C351 are set for adjustment of transport speed.
- Exchange procedures of the special components are same as C450.
For exchange procedures, see the service manual of C450.

5.2 Special Parts List

- LED Drive Board
- Control Board
- LPH Unit
- LPH Assy

Adjustment/Setting

6. Service Mode

6.1 Machine

6.1.1 Fusing Temperature

Functions	<ul style="list-style-type: none"> To adjust individually the temperature of the Heating Roller and the Fusing Pressure Roller for each type of paper, thereby coping with varying fusing performance under changing environmental conditions. * Though all temperatures shown on the screen are 0 °C, they represent the following specific temperatures. <table border="1" data-bbox="283 435 991 635"> <thead> <tr> <th></th> <th>Heating Roller</th> <th>Pressure Roller</th> </tr> </thead> <tbody> <tr> <td>Plain paper</td> <td>190 °C</td> <td>145 °C</td> </tr> <tr> <td>OHP film</td> <td>190 °C</td> <td>170 °C</td> </tr> <tr> <td>Thick 1</td> <td>175 °C</td> <td>130 °C</td> </tr> <tr> <td>Thick 2</td> <td>185 °C</td> <td>130 °C</td> </tr> <tr> <td>Thick 3</td> <td>185 °C</td> <td>130 °C</td> </tr> <tr> <td>Envelope</td> <td>185 °C</td> <td>130 °C</td> </tr> </tbody> </table>		Heating Roller	Pressure Roller	Plain paper	190 °C	145 °C	OHP film	190 °C	170 °C	Thick 1	175 °C	130 °C	Thick 2	185 °C	130 °C	Thick 3	185 °C	130 °C	Envelope	185 °C	130 °C
	Heating Roller	Pressure Roller																				
Plain paper	190 °C	145 °C																				
OHP film	190 °C	170 °C																				
Thick 1	175 °C	130 °C																				
Thick 2	185 °C	130 °C																				
Thick 3	185 °C	130 °C																				
Envelope	185 °C	130 °C																				
Use	<ul style="list-style-type: none"> When fusing performance is poor, or wax streak or offset occurs when the type of paper is changed or environmental conditions change. 																					
Adjustment Range	Heating Roller : -10 °C to +5 °C (step: 5 °C) Plain paper : -5 °C to +5 °C (step: 5 °C) Envelope : -20 °C to +5 °C (step: 5 °C) others Pressure Roller : -20 °C to +5 °C (step: 5 °C) OHP film : -5 °C to +5 °C (step: 5 °C) others																					
Adjustment Instructions	If fusing performance is poor, increase the setting. If wax streaks occur, decrease the setting. If offset is poor, decrease the setting.																					
Adjustment Procedure	<ol style="list-style-type: none"> Call the Service Mode to the screen. Touch these keys in this order: "Machine" → "Fusing Temperature." Select the paper type and Fusing Roller type. Enter the new setting from the +/- key Pad. The temperature does not change immediately when the setting is change. Wait a while before performing the subsequent steps. As a general rule, do not adjust the fusing temperature on the pressure application side. Touch "END" to validate the adjustment value. Check the copy image for any image problem. Make the adjustment for each type of paper. 																					

bizhub C351

Adjustment / Setting

6.1.2 Fusing Transport Speed

Functions	<ul style="list-style-type: none"> To adjust the speed of the Fusing Drive Motor so as to match the fusing speed with transport speed. 								
Use	<ul style="list-style-type: none"> Brush effect or blurred image is evident as a result of changes in environmental conditions or degraded durability. 								
Variable Range	-2 % to +2 % (in 0.1 % increments)								
Adjustment Instructions	If brush effect is evident, vary the setting value and check for image. If a blurred image occurs, decrease the setting.								
Adjustment Procedure	<ol style="list-style-type: none"> Call the Service Mode to the screen. Touch these keys in this order: "Machine" → "Fusing Transport Speed." Select the transport speed, at which the brush effect or blurred image has occurred. <table border="1" data-bbox="252 459 960 612"> <thead> <tr> <th>Transport speed</th> <th>Paper Setting</th> </tr> </thead> <tbody> <tr> <td>(215 mm/s)</td> <td>(Not used) *1</td> </tr> <tr> <td>165 mm/s</td> <td>Plain paper</td> </tr> <tr> <td>60 mm/s</td> <td>Thick paper, OHP film, Envelope, Postcard, Labels: monochrome, color</td> </tr> </tbody> </table> <p>*1: 215 mm/s is displayed on the screen, however it is not used for adjustment. Even if changing 215 mm/s setting, the machine doesn't apply it.</p> <ol style="list-style-type: none"> Enter the new setting from the 10-Key Pad. Touch "END" to validate the adjustment value. Check the copy image for any image problem. <p>* Make the adjustment for each paper type.</p>	Transport speed	Paper Setting	(215 mm/s)	(Not used) *1	165 mm/s	Plain paper	60 mm/s	Thick paper, OHP film, Envelope, Postcard, Labels: monochrome, color
Transport speed	Paper Setting								
(215 mm/s)	(Not used) *1								
165 mm/s	Plain paper								
60 mm/s	Thick paper, OHP film, Envelope, Postcard, Labels: monochrome, color								

6.1.3 Printer Resist Loop

Functions	<ul style="list-style-type: none"> To set the correction value of the paper loop length for each process speed of Tray 1 to Tray 4, Bypass, and Duplex. To adjust the length of the loop formed in paper before the Registration Rollers. Use "Paper Passage" for paper passage check.
Use	When a paper skew occurs. When a paper misfeed occurs.
Adjustment Range	<p>Different setting ranges are set for different transport speeds.</p> <p>(215 mm/s) : (Not used) *1 165 mm/s : -10 to +10 60 mm/s : -15 to +15</p> <p>*1: 215 mm/s is displayed on the screen, however it is not used for adjustment. Even if changing 215 mm/s setting, the machine doesn't apply it.</p>
Adjustment Procedure	<ol style="list-style-type: none"> Call the Service Mode to the screen. Touch these keys in this order: "Machine" → "Printer Resist Loop." Select the transport speed. Enter the new setting from the 10-Key Pad.

Troubleshooting

7. Jam Display

7.1 Solution

7.1.1 Tray 1 take-up, 2nd Image Transfer, Fusing Misfeed

A. Detection Timing

Type	Description
2nd Image Transfer, Fusing misfeed detection	The leading edge of the paper does not block the Exit Sensor (PC30) even after the lapse of a given period of time after the Registration Roller Clutch has been energized.
	The Registration Roller Sensor (PC28) is not unblocked even after the lapse of a given period of time after it has been blocked by the paper. (Except when feeding the paper from Tray 1)
Tray 1 take-up misfeed detection	The leading edge of the paper does not block the Registration Roller Sensor (PC28) even after the lapse of a given period of time after the Tray 1 Paper Feed Clutch (CL1) has been energized. (When the system speed is 60 mm/s or 165 mm/s)
Misfeed detected as a result of delayed deactivation of sensor	The Registration Roller Sensor (PC28) is not unblocked even after the lapse of a given period of time after it has been blocked by the paper. (When the system speed is 60/mms or 165 mm/s)
Detection of paper left in 2nd Image Transfer	The Registration Roller Sensor (PC28) is blocked when the Main Power Switch is turned ON, a door or cover is opened and closed, or a misfeed or malfunction is reset.
	The OHP Sensor (PC27) is blocked when the Main Power Switch is turned ON, a door or cover is opened and closed, or a misfeed or malfunction is reset.
Detection of paper left in Tray 1	Tray 1 Double Feed Sensor (PC1) is blocked when the Main Power Switch is turned ON, a door or cover is opened and closed, or a misfeed or malfunction is reset.

B. Action

Relevant Electrical Parts	
Tray 1 Double Feed Sensor (PC1) Registration Roller Sensor (PC28) Exit Sensor (PC30) OHP Sensor (PC27)	Control Board (PWB-MC) Registration Roller Clutch (CL3) Tray 1 Paper Feed Clutch (CL1)

Step	Action	WIRING DIAGRAM	
		Control Signal	Location (Electrical Component)
1	Initial check items	—	—
2	PC1 I/O check, Sensor check	PWB-MC PJ22MC-8 (ON)	C to D-5
3	PC28 I/O check, Sensor check	PWB-MC PJ24MC-6 (ON)	C to D-3
4	PC30 I/O check, Sensor check	PWB-MC PJ24MC-12 (ON)	C to D-4
5	PC27 I/O check, Sensor check	PWB-MC PJ24MC-2 (ON)	C to D-3
6	CL3 operation check	PWB-MC PJ24MC-14 (ON)	C to D-4
7	CL1 operation check	PWB-MC PJ14MC-3 (ON)	C to D-5 to 6
8	Change PWB-MC	—	—

bizhub C351

Troubleshooting

Appendix

8. Parts layout drawing

8.1 DF-601 (Option)

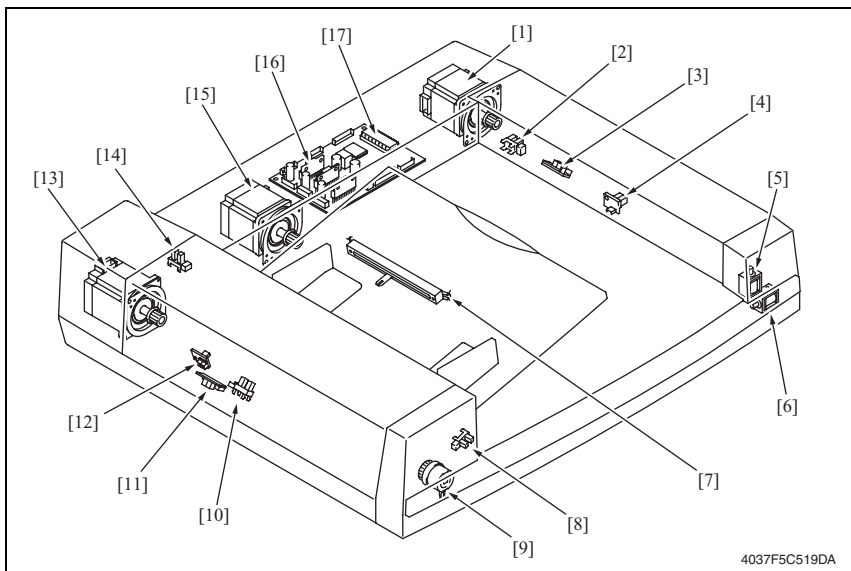

4037F5C519DA

- | | |
|-------------------------------------|------------------------------------|
| [1] Exit Motor (M3-DF) | [10] Empty Sensor (PC4-DF) |
| [2] Exit Cover Sensor (PC7-DF) | [11] Pick-up Sensor (PC2-DF) |
| [3] Exit Sensor (PC6-DF) | [12] Registration Sensor (PC1-DF) |
| [4] Turnover Sensor (PC5-DF) | [13] Take-up Motor (M1-DF) |
| [5] Exit Solenoid (SL2-DF) | [14] Take-up Cover Sensor (PC3-DF) |
| [6] Turnover Solenoid (SL1-DF) | [15] Transport Motor (M2-DF) |
| [7] Document Size Volume (R1-DF) | [16] Control Board (PWB-A DF) |
| [8] Tray Open/Close Sensor (PC8-DF) | [17] ROM (IC7-DF) |
| [9] Registration Clutch (CL1-DF) | |

9. Timing chart

9.1 DF-601 (Option)

1-sided mode

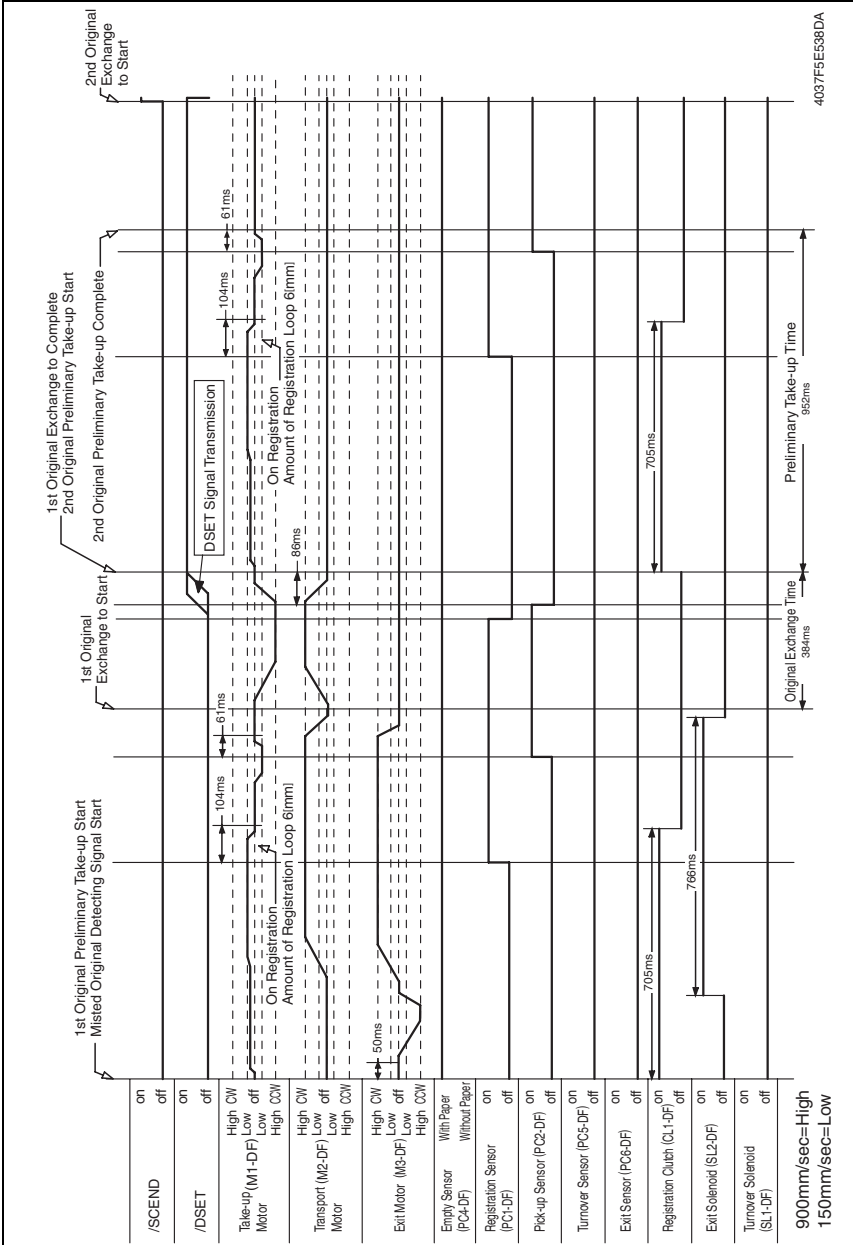

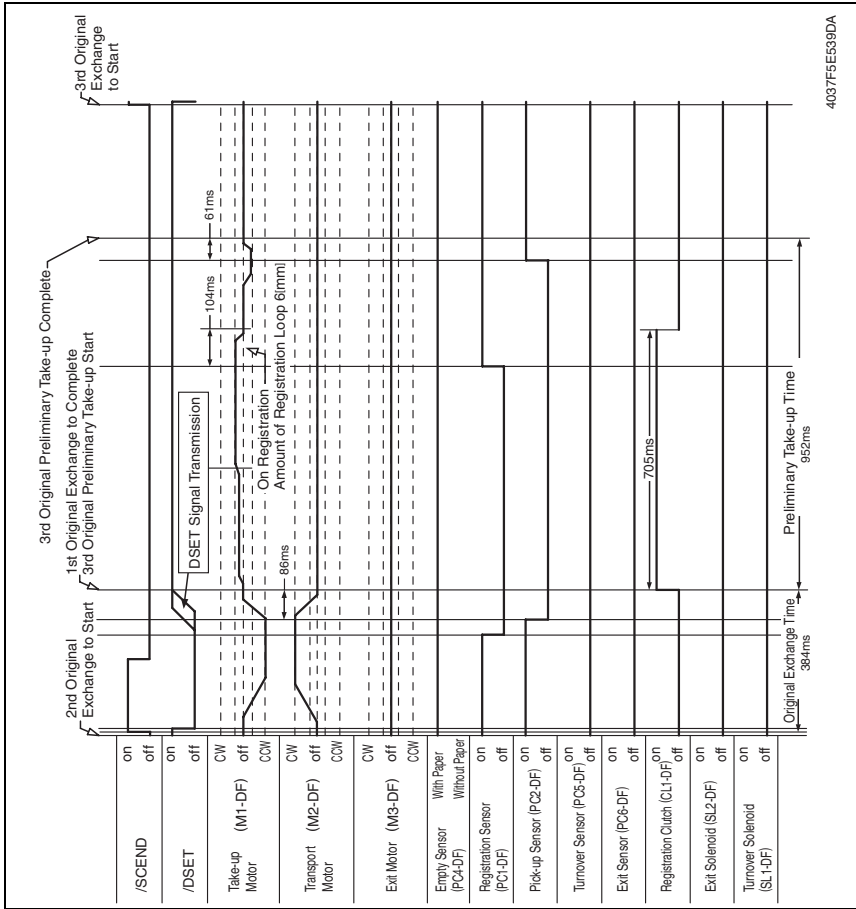

4037F5EES9DA

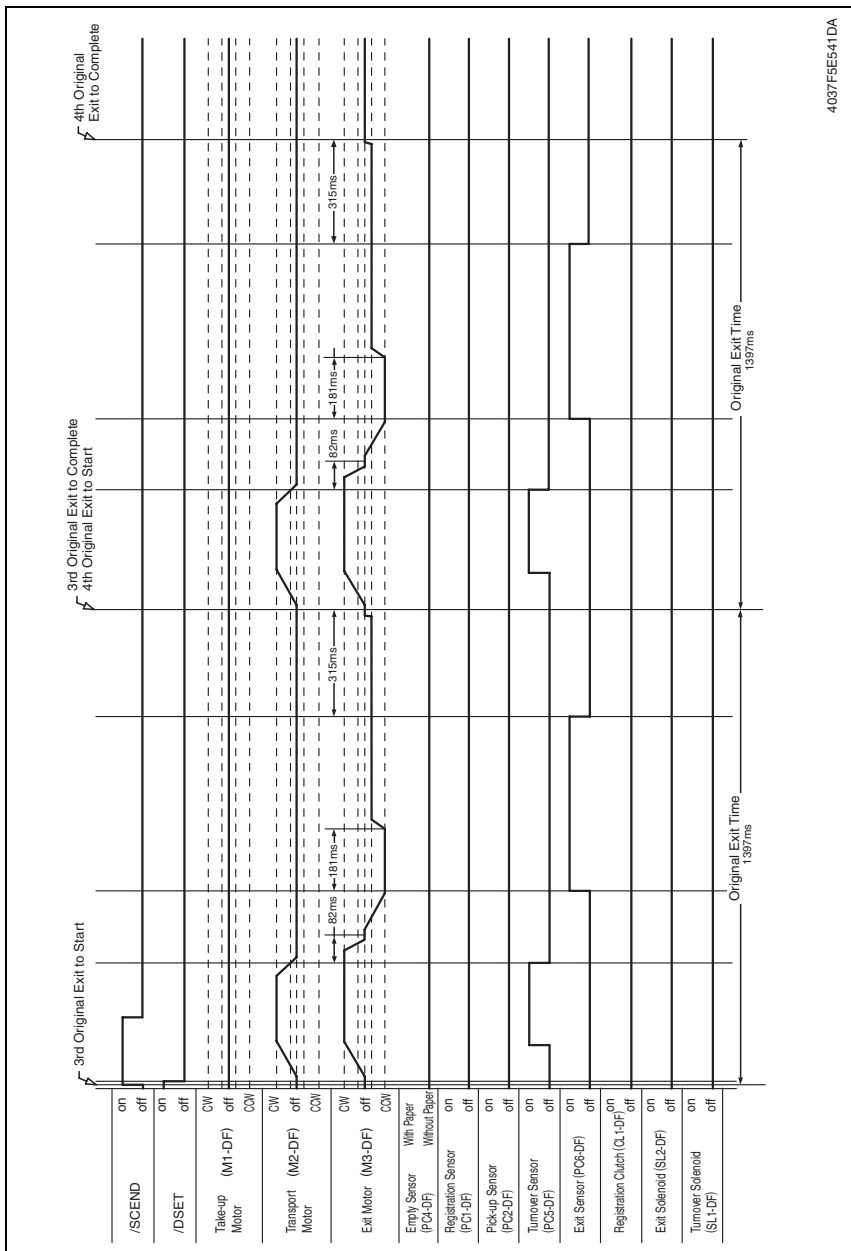

4037FE541DA

bizhub C351

Appendix

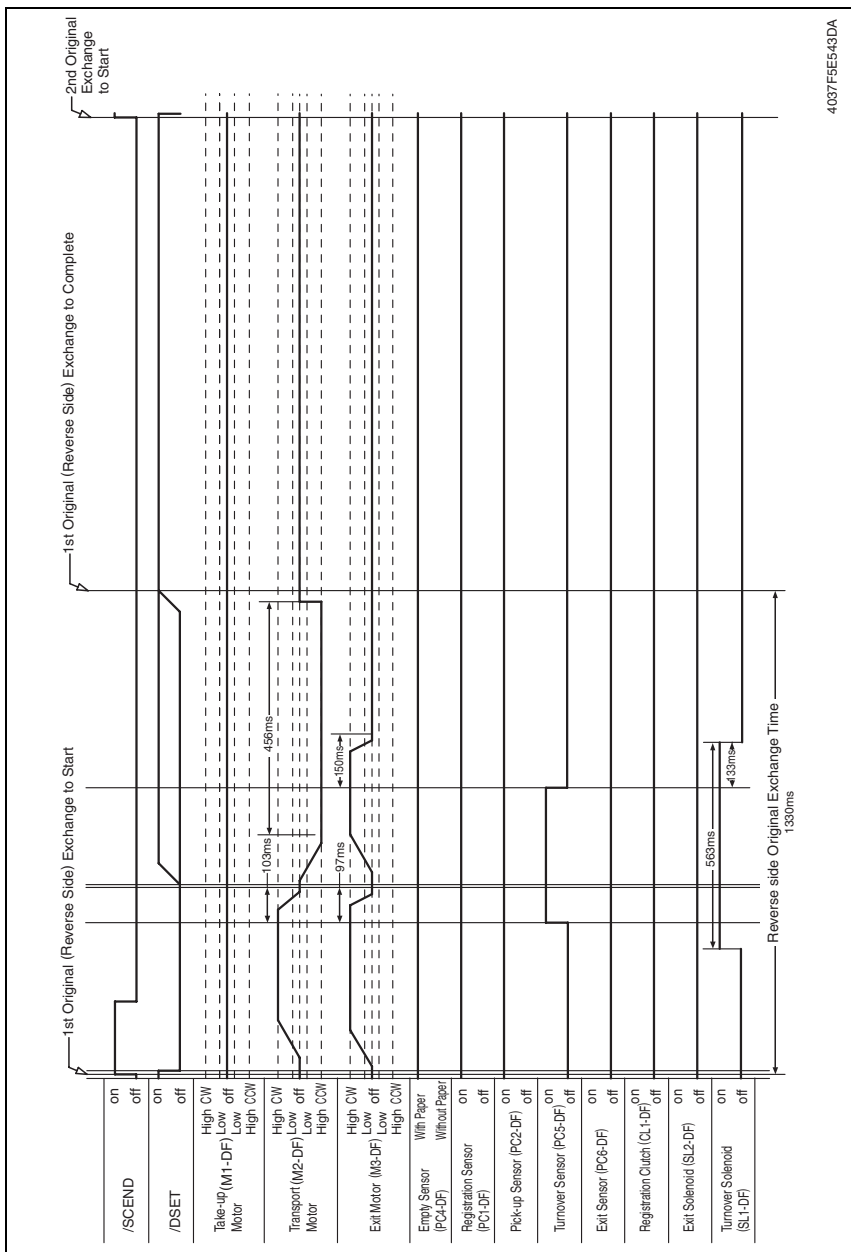

bizhub C351

Appendix

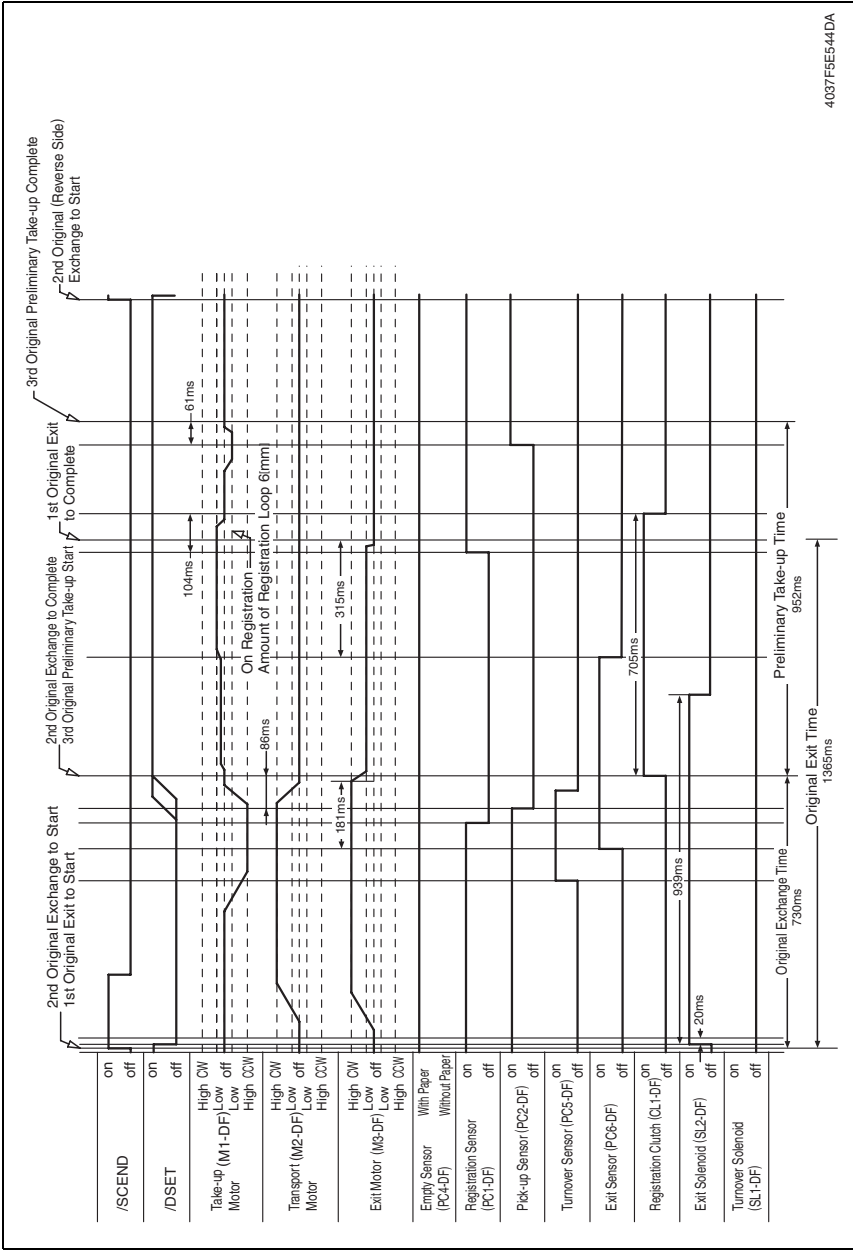

4037F5E544DA

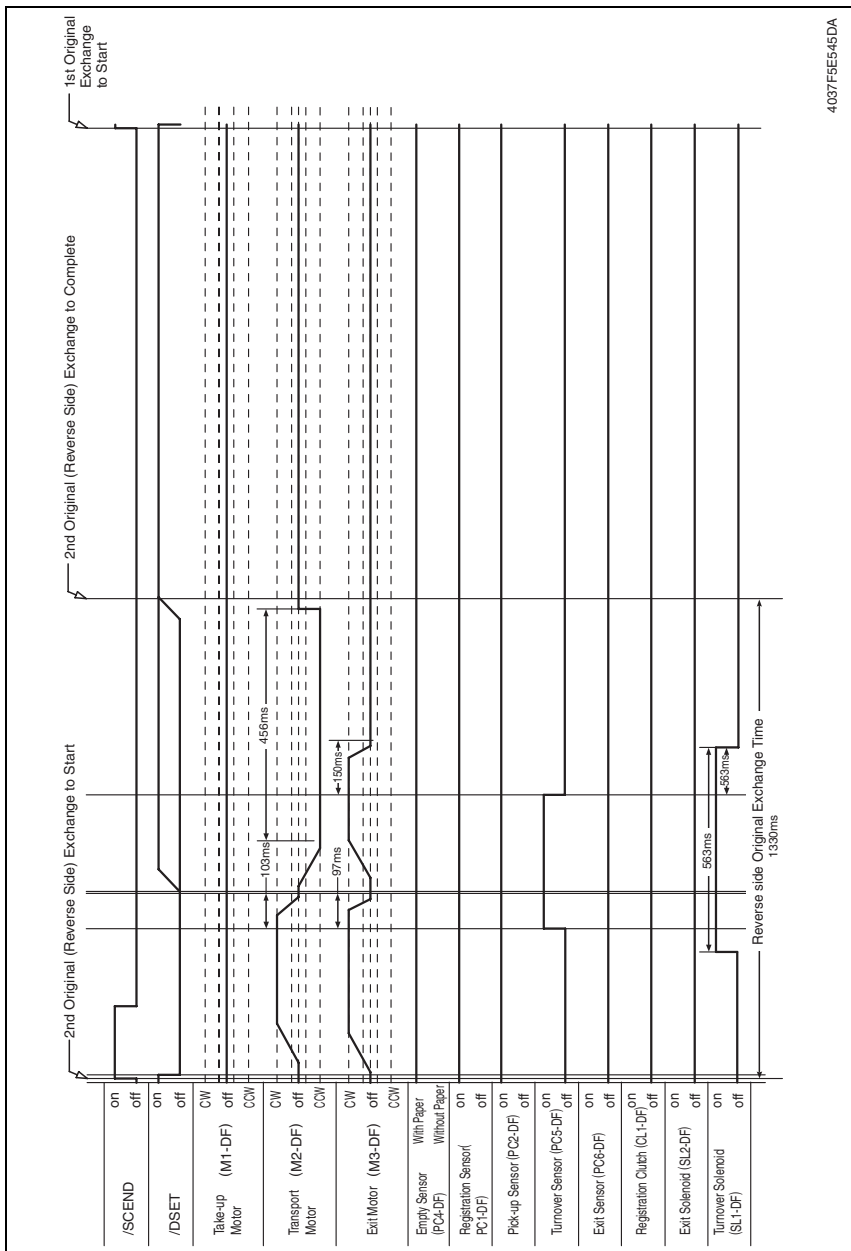

4037FEE545DA

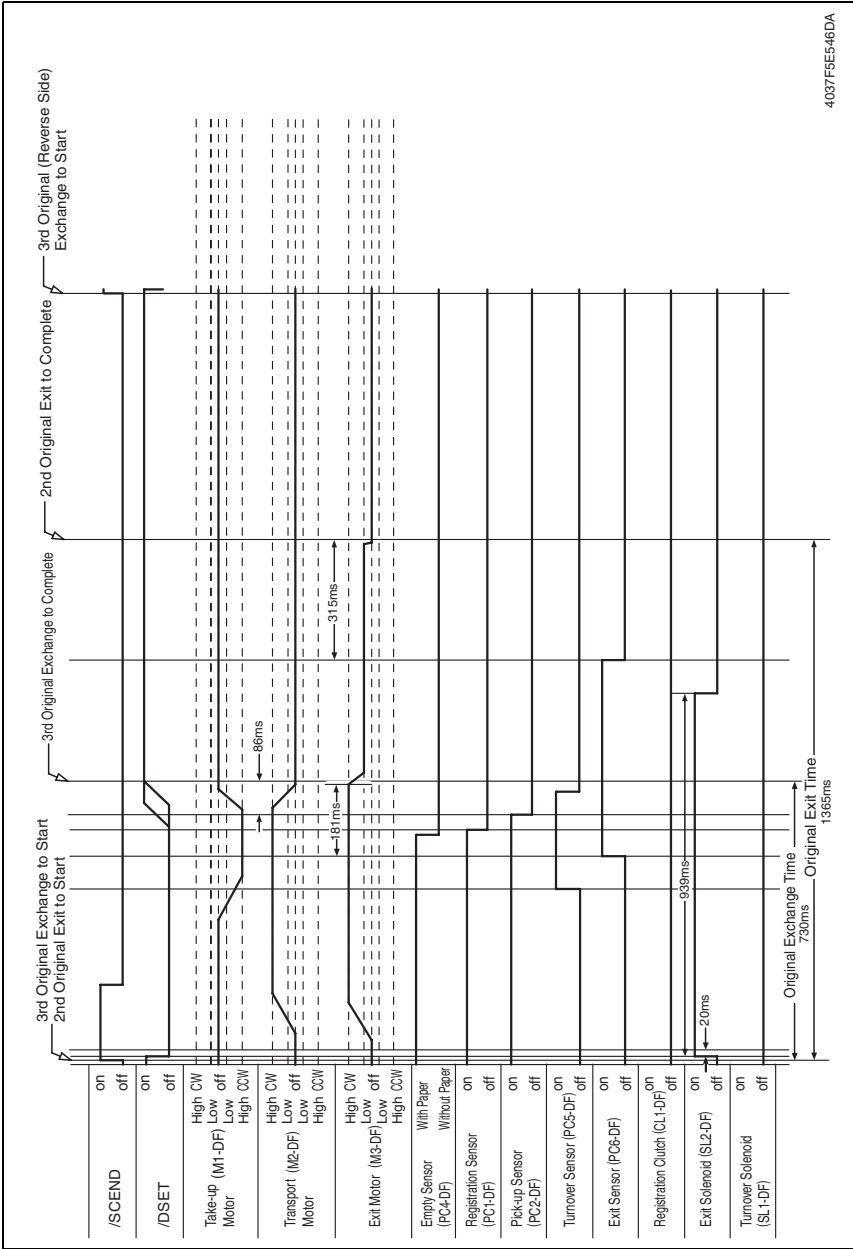

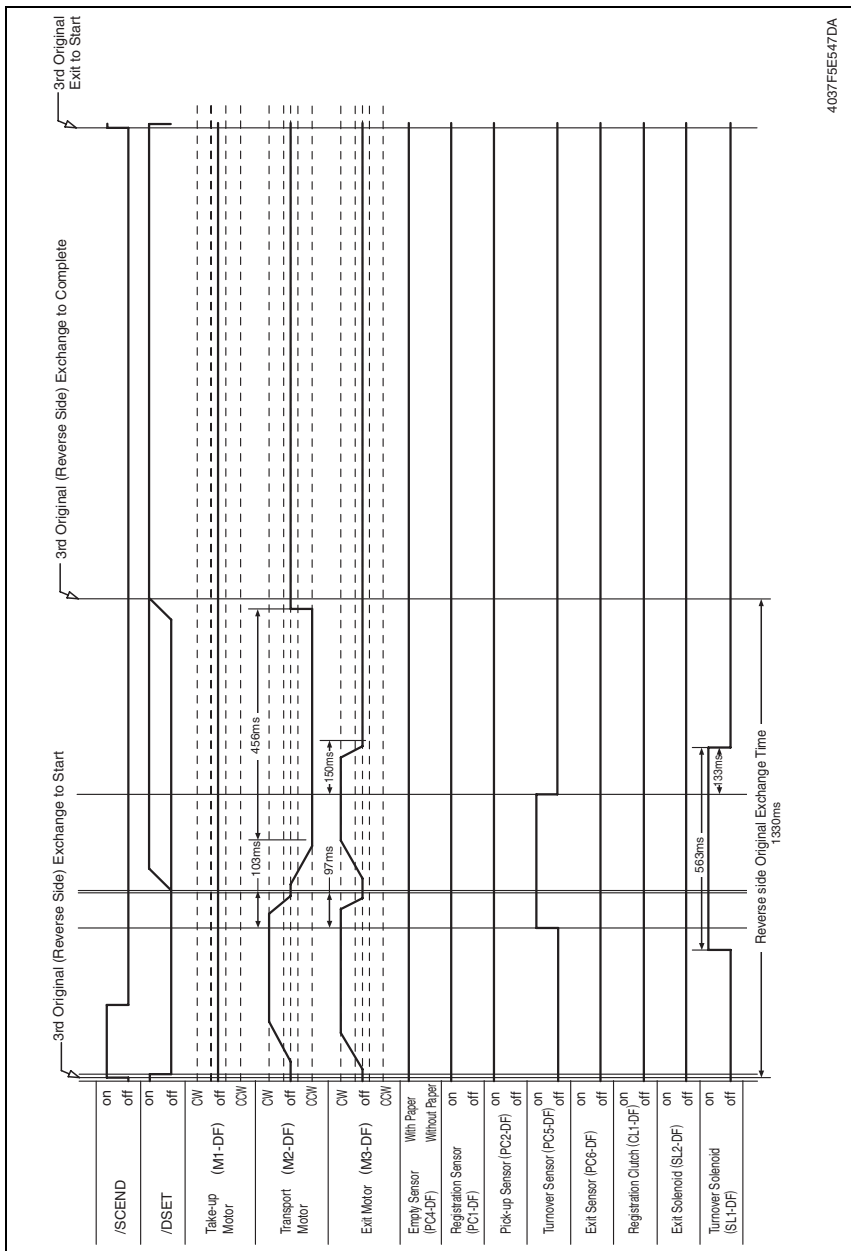

4037FEES47DA

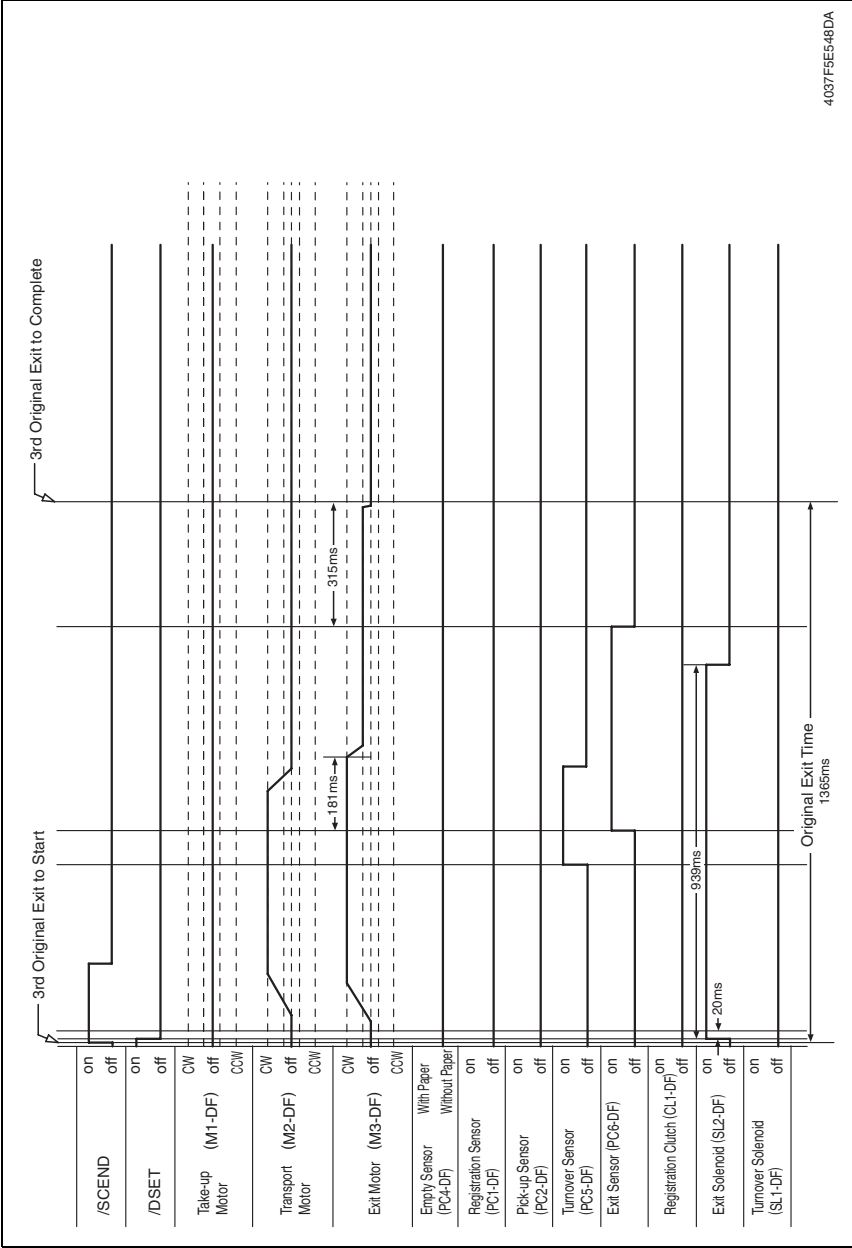

4037F6E548DA



KONICA MINOLTA

© 2005 KONICA MINOLTA BUSINESS TECHNOLOGIES, INC.

Use of this manual should be strictly supervised to
avoid disclosure of confidential information.

Printed in Japan
DD4037PE1-P000